

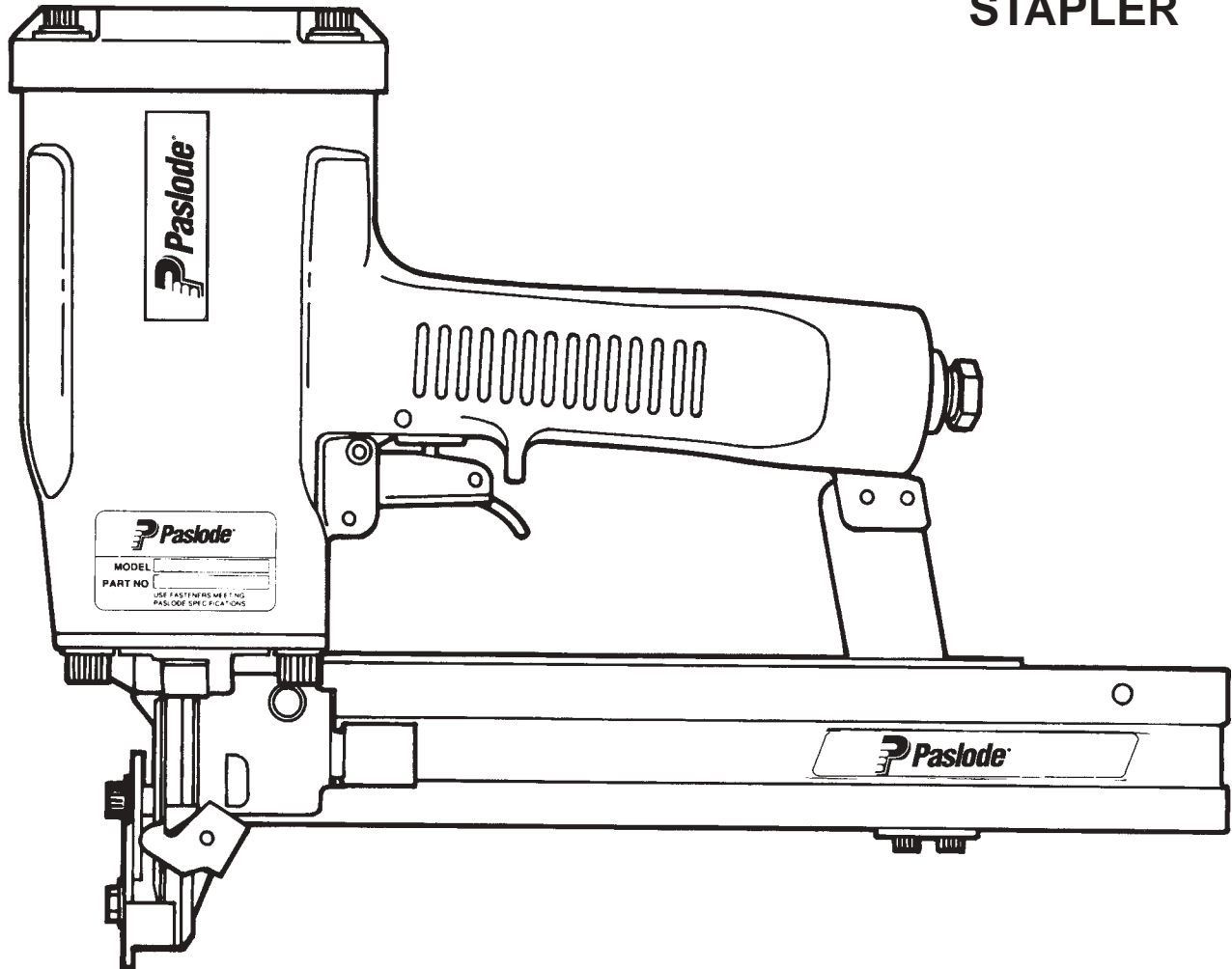

MODEL 4150/38 W14
STAPLER



TOOL SCHEMATIC AND PARTS

IMPORTANT!

DO NOT DESTROY

Always refer to safety and maintenance manual #403606 for detailed information on this tool. It is the customer's responsibility to have all operators and service personnel read and understand this information.

PARTS LEGEND

Model 4150/38 W14, 405194

1	404229	4	S.H.C.S. 1/4-20 x 2-1/4"	45	096893	1	Nameplate
3	091447	4	Washer	*46	091208	1	O-Ring, Housing
4	402979	4	Spacer, Diffuser	47	402983	1	Flange, Nose
5	402978	1	Cap, Diffuser	49	009016	4	S.H.C.S. 5/16-18 x 1"
6	500011	1	Cap	52	092037	2	Lock Nut, 10-32
7	402955	1	Gasket, Cap	53	403716	2	S.H.C.S. 10-32 x 5/16"
8	402959	1	Spring, Main Valve	54	405202	1	Rail Bracket
9	500322	1	Retaining Ring	55	402738	1	Spring
*10	402962	1	O-Ring, Upper Valve Piston	56	402629	1	Hardened Washer
11	402941	1	Upper Valve Piston	57	405200	1	Intermediate W.C.E.
*12	092729	1	O-Ring, Lower Valve Piston	60	406039	1	Work Contacting Element
*13	004163	1	O-Ring, Lower Valve Piston	→ 61	501211	1	Front Guide
*14	402974	1	O-Ring, Lower Valve Piston	62	009037	2	S.H.C.S. 1-32 x 1/2"
15	500321	1	Lower Valve Piston	63	501205	1	Back Plate
16	405211	1	Seal, Main Valve	64	404698	2	Roll Pin assembly
*17	402963	1	O-Ring, Main Valve Post	65	402730	1	Pivot Pin, Front Guide
18	402944	1	Post, Main Valve	66	405078	1	Spring, Front Latch
▲ 19	070502	1	B.H.Mach.S. 8-32 x 5/8"	67	501207	1	Latch, Front Guide
20	500726	1	Gripco Nut, Special	68	501209	1	Latch Pin
21	095412	1	Washer, Driver Blade	* * 69	500459	1	Warning Label
*22	091967	1	O-Ring, Piston	70	402748	1	Pivoting Rail Cover Assembly
23	500725	1	Piston	71	404848	1	Rail & Rail Cover Assembly
▲ *24	401229	1	Driver Blade	72	402731	1	Logo, Magazine
25	402954	1	Seal, Sleeve	73	402740	1	Roll Pin 3/32 x 7/16"
26	500583	1	Sleeve	▲ 75	091568	1	Binding Hd. Screw, 6-32 x1/4"
*27	402961	1	O-Ring, Sleeve	76	091532	1	Negator
*28	402728	2	O-Ring, Sleeve	77	091534	1	Drum, Negator
*29	405197	1	Bumper	78	402743	1	Pin, Negator Drum
30	500010	1	Sleeve, Bumper	79	402759	1	Spring, Follower Latch
31	402079	1	Pin, Trigger	80	402758	1	Follower Latch
32	404938	2	Logo, Housing	81	402486	1	Retaining Washer
33	402926	1	Housing	82	405201	1	Follower
34	091622	1	Reducing Pipe Bushing	83	402668	2	Retaining Ring
35	097748	1	Spring, Valve Pin	84	091591	1	O-Ring
36	097746	1	Valve Pn	85	401940	1	End Plug
37	401958	1	Valve Body	86	405196	1	Sleeve, Bumper
38	026133	2	Roll Pin 1/8" x 1"	87	405147	1	Lever, Trigger
*39	092174	1	O-Ring, Valve Body	88	005849	1	Roll Pin
40	405144	1	Trigger	89	405209	1	Spacer
41	404325	1	Stop Nut	90	402734	1	Spring, W.C.E.
42	405198	1	Seal, Lower	91	406010	1	Flange, Sleeve
43	094295	1	O-Ring	92	401952	1	O-Ring
44	500488	1	Grip, Handle				

* Denotes normal wear items

** Make sure Warning Label (500459) is properly affixed.
Replace if necessary. Label available at no charge
through Service Department.

▲ Apply Loctite 242 (Blue)

→ Denotes New Change

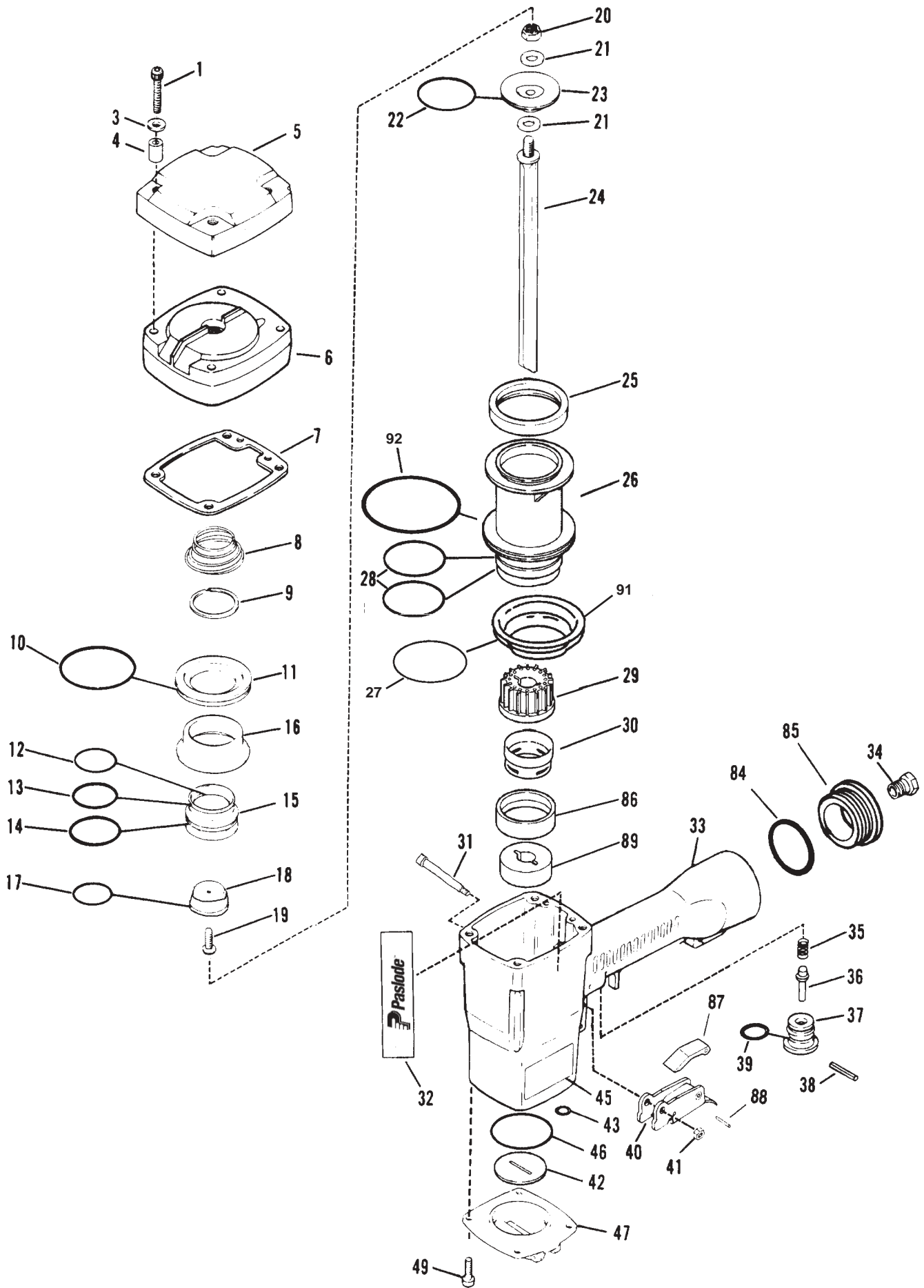

4150/38 W14

405194

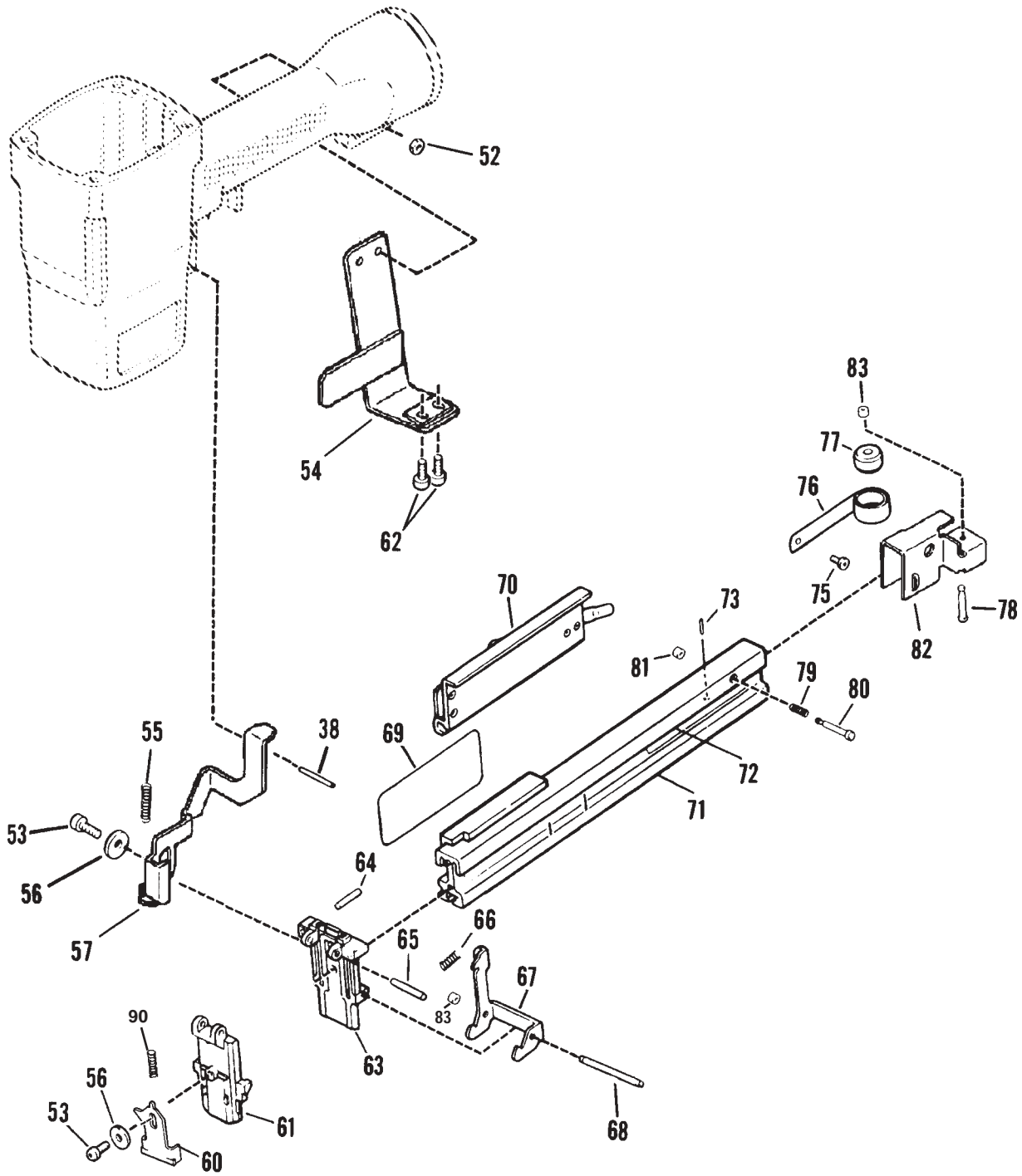

PARTS OFFERED AS ASSEMBLIES

403236 Piston Assembly

Includes

20	500726	1	Gripco Nut, Special
21	095412	2	Washer, Driver Blade
22	091967	1	"O" Ring, Piston
23	500725	1	Piston
24	401229	1	Driver Blade

500237 Cap Assembly

Includes

6	500011	1	Cap
8	402959	1	Spring, Main Valve
9	500322	1	Retaining Ring
10	402962	1	"O"Ring Upper Valve Piston
11	402941	1	Upper Valve Piston
12	092729	1	"O"Ring, Lower Valve Piston
13	004163	1	"O"Ring, Lower Valve Piston
14	402974	1	"O"Ring, Lower Valve Piston
15	500321	1	Lower Valve Piston
16	405211	1	Seal, Main Valve
17	402963	1	"O" Ring, Main Valve Post
18	402944	1	Post, Main Valve
19	070502	1	Button Head Machine Screw #8-32 x 5/8"

405212 Main Valve Assembly

Includes

9	500322	1	Retaining Ring
10	402962	1	"O" Ring, Upper Valve Piston
11	402941	1	Upper Valve Piston
12	092729	1	"O"Ring, Lower Valve Piston
13	004163	1	"O"Ring, Lower Valve Piston
14	402974	1	"O"Ring, Lower Valve Piston
15	500321	1	Lower Valve Piston
16	405211	1	Seal, Main Valve

402408 Trigger Assembly

Includes

31	405144	1	Trigger
90	405147	1	Lever, Trigger
91	005849	1	Roll Pin

AIR CONSUMPTION CHART

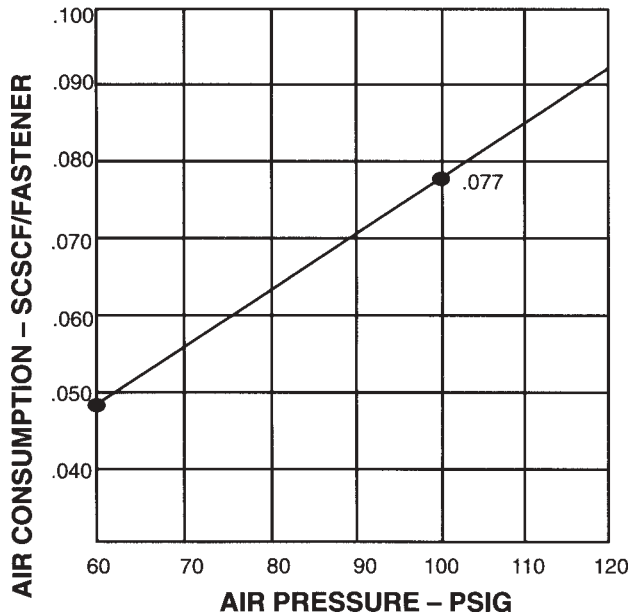

SAFETY INSTRUCTIONS

WEAR EYE AND HEARING PROTECTION



Always wear hearing protection and eye protection devices, including side shields when operating or working in the vicinity of a tool.



**DO NOT EXCEED MAXIMUM
RECOMMENDED AIR PRESSURE**

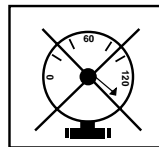

Operate the tool using only the recommended air pressure. Do not exceed the maximum air pressure marked on the tool. Be sure the air pressure gauge is operating properly and check it at least twice a day.

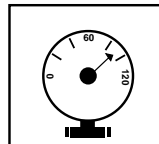

Never use any bottled air or gases such as oxygen to operate the tool since they could cause the tool to explode.

ACCESSORIES

Sequential Operating Kit

This special attachment is designed for sequential operation (stops "contact" firing). The operator must depress and hold the work contacting element against the work surface before pulling the trigger. This sequence must be repeated each time the tool drives a fastener.

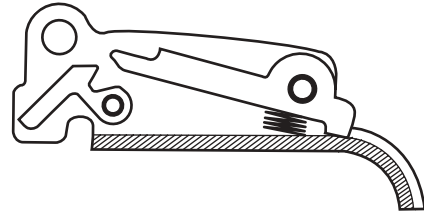

Part No. 406006

Remote Fire Valve

This valve via a positive air signal allows a machine mounted tool to be operated from an automatic air valve or foot pedal system.

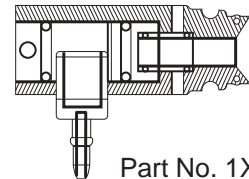

Part No. 1X0713

Lubricants and Loctite

Chemplex 710 Lubricant 1 lb.
Lubricating Oil 8 oz.
Lubricating Oil 8 oz. with Antifreeze
Loctite 242 (Blue) 1 oz.



Part No. 403734
Part No. 219026
Part No. 219090
Part No. 093500

Degreaser Cleaner

Ideal cleaner for all Paslode tools.



Part No. 219086

Belt Hook

Attaches to cap of tool enabling you to carry tool on belt holder (offered below).

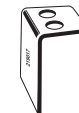

Part No. 219017

Belt Hook Holder

Attaches to work belt and carries tool using the above belt hook.

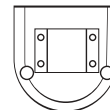

Part No. 219028

Safety Glasses

Clear
Tinted



Part No. 402510
Part No. 402512

Trigger Valve Repair Kit

This kit repairs all trigger valve air leaks.

Part No. 219224

Large Nylon Carrying Case



Part No. 219246



An Illinois Tool Works Company
888 Forest Edge Drive
Vernon Hills, Illinois 60061